



Operating Manual

AI02-INSP Series





Contents

1. About This Manual

1.1 Products Covered by This Manual	01
1.2 Target Group	01
1.3 Symbols Used	01
1.4 Storage of the Manual	01

2. Safety

2.1 Intended Use	02
2.2 Important Safety Instructions	02
2.3 Storage and Transportation	03

3. Scope of Delivery

4. Product Description

4.1 View of the Inverter	05
4.2 Topology of the Battery	06
4.3 System Diagram	07
4.4 Operating Mode Introduction	07

5. Mounting

5.1 Requirements for Mounting	08
5.2 Mounting the Inverter (with AI02-BTLVP-5KWH battery)	10
5.3 Mounting the Inverter (with AI02-BTLVP-11KWH battery)	14

6. Electrical Connection

6.1 Wiring Diagram for Australia	19
6.2 Wiring Diagram for General	20



6.3 Overview of the Connection Area	21
6.4 PV Connection	22
6.5 Grid Connection	23
6.6 EPS Connection	24
6.7 Battery Connection	26
6.8 Smart Meter Connection	28
6.9 Qendercore Hub Connection	32
6.10 DRM Connection	33
6.11 Paralleling Connection	33
6.12 Battery Paralleling Connection	34

7. Operating of the Inverter

7.1 Graphical Display	35
7.2 Operating of the Battery	36
7.3 Commissioning	37
7.4 Decommission	37
7.5 Network Configuration	38

8. Troubleshooting and Maintenance

8.1 Troubleshooting	41
8.2 Maintenance	47

9. Technical Data

9.1 Specification of inverter	48
9.2 Specification of battery	49
9.3 Certificates and Grid Regulations	50

10. Contacts



1. About This Manual

1.1 Products Covered by This Manual





AI02 Series Low Voltage Solar Hybrid Inverter:
AI02-INSP-3680, AI02-INSP-5000, AI02-INSP-6000

1.2 Target Group

This document is intended for qualified electricians. Any electrical installation and maintenance on this inverter must be performed by qualified electricians in compliance with standards, wiring rules or requirements of local grid authorities or bodies.

1.3 Symbols Used

These important instructions must be followed during installation, operation and maintenance of the inverter.

	DANGER indicates a hazardous situations which if not avoided will result in death or serious injury.
	WARNING indicates a hazardous situations which if not avoided could result in death or serious injury.
	CAUTION indicates a hazardous situations which if not avoided could result in minor or moderate injury.
	NOTICE Indicates a situation which, if not avoided, can result in property damage.

1.4 Storage of the Manual

The manual should be stored with other documents belonging to the inverter and must be available to people authorized to work on the installation.

Note: This manual will be updated if necessary. Please check www.soltaro.com for more information.



2. Safety

2.1 Intended Use

The AI02 Series are single phase solar hybrid inverters suitable for both on-grid and off-grid operation. With Lithium batteries, PV panels and a smart meter, the hybrid inverter is the central device to make a solar storage system for increased self-consumption.

The AI02-INSP Series must only be connected with the lithium battery from SOLTARO.

To prevent personal injury and property damage and to ensure long-term operation of the product, please read and follow all the instructions and cautions on the inverter and this user manual during installation, operation or maintenance at all times.

2.2 Important Safety Instructions



Danger to life from electric shock.

- Before performing any work on the inverter, disconnect all DC and AC power from inverter and wait for at least 5 minutes.
- Do not touch DC conductors or any non-isolated cable ends.
- If an error occurs, contact your local distributor or a qualified electrician.
- Only authorized service personnel are allowed to install the inverter or perform servicing and maintenance.
- All power, both AC and DC, should be disconnected from inverter before attempting any maintenance or cleaning or working on any circuits connected to inverter.



Risk of burns from hot surfaces.

- The surface of the inverter might exceed 60°C, touching the surface may result in burns.
- Make sure the inverter is not touchable by children.



- The Inverter has a transformerless design on the PV side. Either positive or negative terminals of PV panels should not be grounded.
- The frames of PV panels should be grounded for safety reasons.

NOTICE

- Do not open inverter cover or change any components without authorization, otherwise the warranty commitment for the inverter will be invalid.
- Appropriate methods must be adopted to protect inverter from electrostatic discharge, any damage caused by ESD is not warranted by the manufacturer.

2.3 Storage and Transportation

- Store the inverter in a dry environment where ambient temperature is always between -30°C and +60°C. Take care of the inverter during storage and transportation.
- The package shall not be tilted or inverted during transportation, handling and storage.
- When the inverter or other related components need to be disposed, make sure it is carried out according to local waste handling regulations.
- Please be sure to deliver waste inverters and packing materials to appropriate recycling centers where possible.

2.4 Pre-installation Check

According to the packing list, check whether the components are complete and in good appearance. If any abnormality occurs, contact your sales agent in time.

Parts and accessories supplied with the packing box are personal as sets of the owner and must not be taken away from the installation site. Check personal protective equipment and installation tools to ensure that they are complete; if not, please make them up. Check the customer-provided cable to ensure that the quantity and specifications are correct, if not, prepare again.

Protective equipment



Installation tool

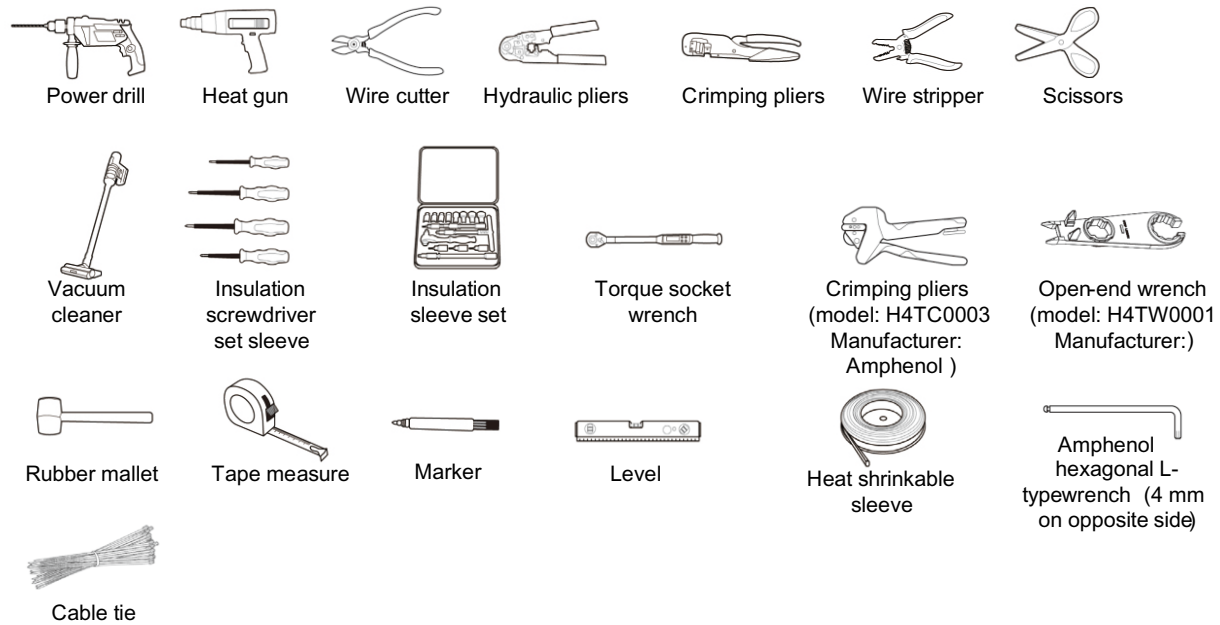

3. Scope of Delivery

Inverter	Wall Mounting Bracket	Battery power cables
GRID Connector	EPS Connector	RJ45 Connector for DRM port
PV Connectors*2Pairs	BMS Cable	CT and Smart Meter
M5 Screws*10PCS	Expansion Screws*20PCS	Certificate card
User Manual	Qendercore Hub(Wi-Fi & LAN Stick)	16pin Multi port connector

4. Product Description

4.1 View of the Inverter

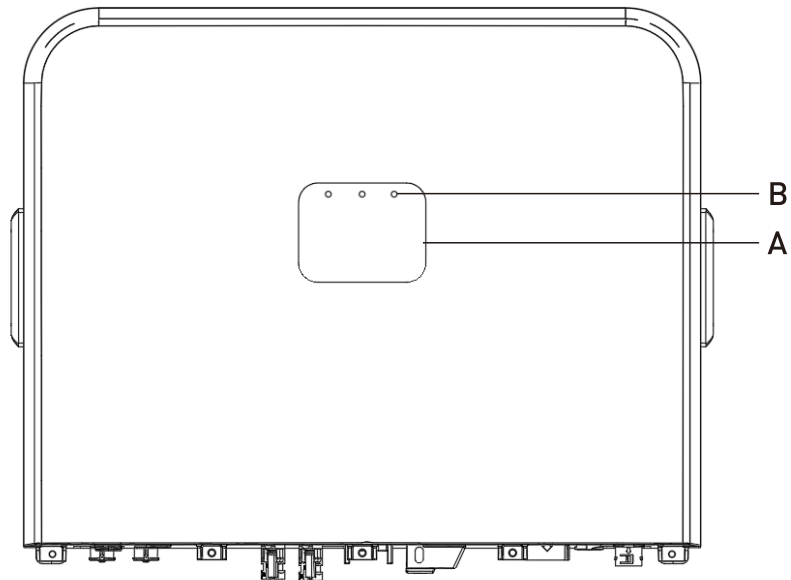

Figure 1. View of the AI02 Series Hybrid Inverter

Position	Designation
A	Graphical Display
B	LED

Icons on the Nameplate

Symbol	Explanation
	CE Mark.
	UKCA Mark.
	UKNI Mark.
	Caution, Risk of Danger.
	Caution, Risk of Electric Shock.
	Caution, Hot Surface.

	Caution, Hot Surface.
	Refer to the Operating Manual.
	Danger, Risk of Electric Shock due to Stored Energy. Cut off all power and wait at least 5 minutes before any work is carried out on the inverter.
	RCM Mark for Australia and New Zealand.
	WEEE Mark. This inverter should not be disposed as ordinary waste.

4.2 Topology of the Battery

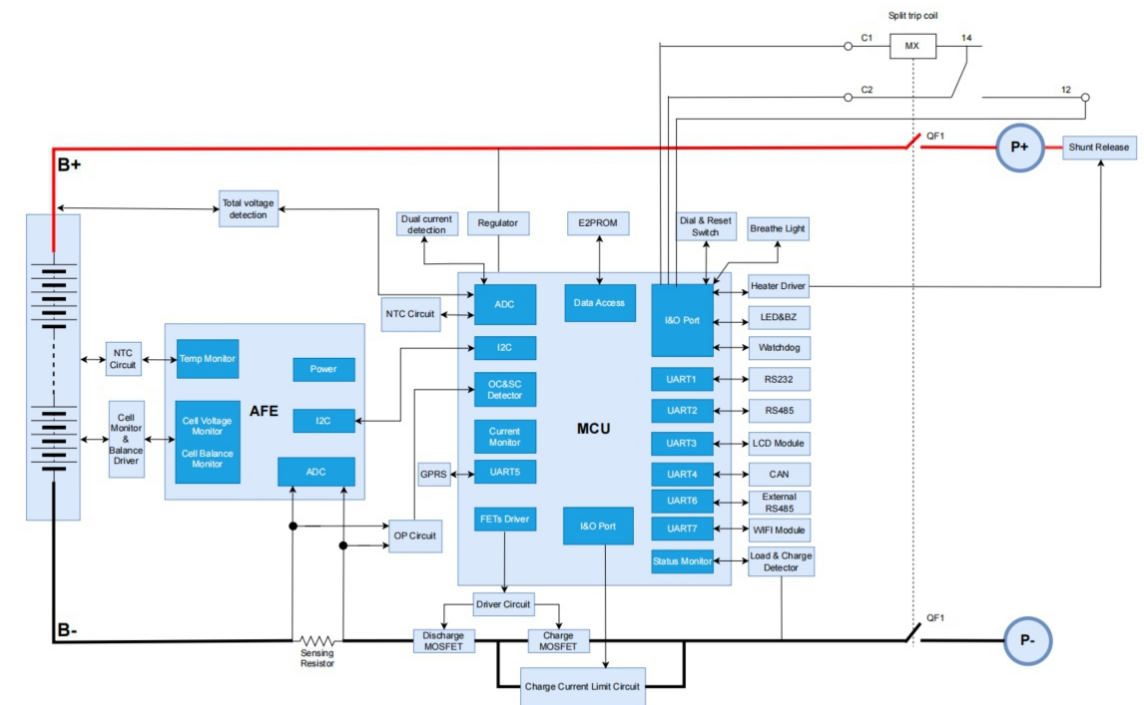
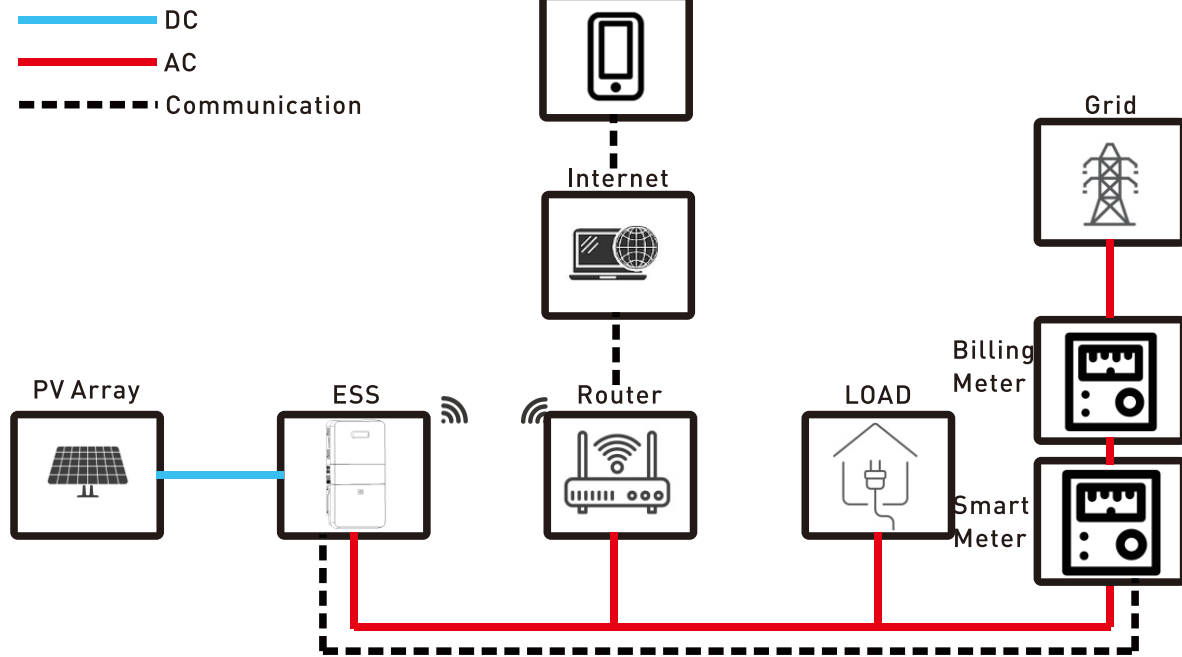

Figure 2. AI02-INSP Battery topology

When a battery cell exceeds the protection limits (voltage, current, and temperature) during use, it cannot be automatically reset or reset by the user directly. Only the manufacturer or maintenance personnel can reset it.

4.3 System Diagram



4.4 Operating Mode Introduction

4.4.1 On Grid Operating Mode

When the energy storage inverter operates in grid connected mode, you can set a priority mode according to your needs. The user can set it through APP, each priority mode can have up to three time periods.

- **Load priority:** The default mode is load priority. When the system operates in this mode, PV power will prioritize feeding the onsite load. When the onsite load demands cannot be met by PV power, the battery begins to discharge. When the PV power generation exceeds the load demand, the battery begins to charge from the excess power. If the battery is fully charged, excess power will be exported to the grid (unless export limitation has been set).
- **Battery priority:** When the system operates in this mode, it will give priority to charging the battery. When it is necessary to start the mains power to charge the battery, use The household needs to enable AC charging (mains charging) function, and set the start and end charging time as well as the battery SOC point. If the AC charging (mains charging) function is not enabled, the energy storage inverter will only be able to charge the battery through photovoltaics. In addition, customers can also set the power percentage, which is the maximum power at which the battery operates. In battery priority mode, the battery discharge cannot exceed this limited power value.
- **Grid priority:** When the system operates in this mode, the electricity generated by photovoltaics will be prioritized for grid connection. Users can deliver electricity during peak hours To the power grid, in this mode, users can set the start and end charging times as well as the battery SOC point. In addition, customers can also set the power percentage, which is set to the maximum power of the battery operation. In the grid priority mode, the battery discharge cannot exceed this limit power value.

4.4.2 Off Grid Operating Mode

When the power grid is cut off, the system will automatically switch to off grid mode (users can turn off this function), At this point, the EPS output port will output voltage, and the system will supply power to the load through batteries and solar energy. It should be noted that in this mode, The maximum output power of the energy storage inverter is 6000W, so the load power of the EPS port should not exceed 6000W.

5. Mounting

5.1 Requirements for Mounting



- Check to make sure the installation site does not fall into any of the following conditions: If it does, then a risk assessment will be required.
- DO NOT install the inverter in a place where personnel are likely to come into contact with its enclosure and heat sinks because these parts are extremely hot during operation.
- Select an optimal mounting location for safe operation, long service life and expected performance. Make sure the installation avoids the following conditions:
 - Unsafe due to assessment of occupational health safety risks.
 - The ambient temperature is outside the range of tolerable ambient temperature (-30°C to +60°C, -22°F to +140°F).
 - Higher than the altitude of 2,000m above sea level. Above 2000m the inverter output will be de-rated.
 - Close to flammable materials or areas where flammable materials are stored.
 - Prone to be damaged by seawater.
 - Prone to be flooded or high levels of snowfalls.
 - Close to corrosive gas or liquid (For example, installed in a location with a high corrosivity value (eg.C4 or higher from ISO9223)).
 - Exposed to direct sunlight or in an enclosure exposed to direct sunlight.
 - Installed close to localized heat sources.
 - Mounted on a surface without suitable fire/heat rating.
 - Mounted on a wall without suitable load bearing capability.
 - High humidity.
 - Site is considered unsafe because of local regulations.
 - Confined space without adequate airflow.
 - Area subject to sand or dust storms.
 - Exposed to steam, vapor, or water.
 - Near antenna and/or data cables.
- Electrical Installation & Maintenance in Australia shall be conducted by a licensed electrician and shall comply with Australia National Wiring Rules.
- The battery system can be installed indoors or outdoors.



Risk of burns from hot surfaces.

- The surface of the inverter might exceed 60°C, touching the surface may result in burns.
- Do not touch DC conductors or any non-isolated cable ends.
- Make sure the inverter is not touchable by children.

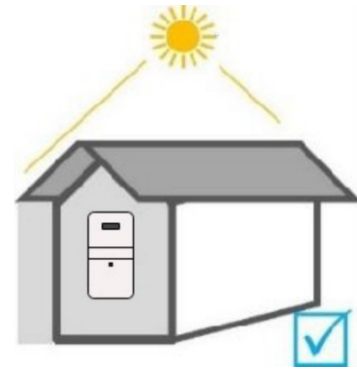

No direct sunlight (Shaded)

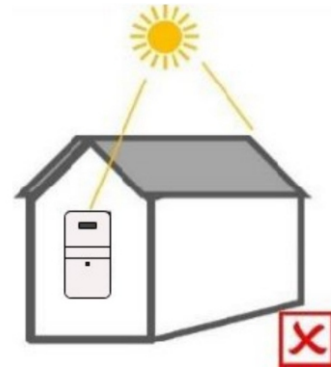

Direct sunlight

Clearance Requirement (Indoor installation)

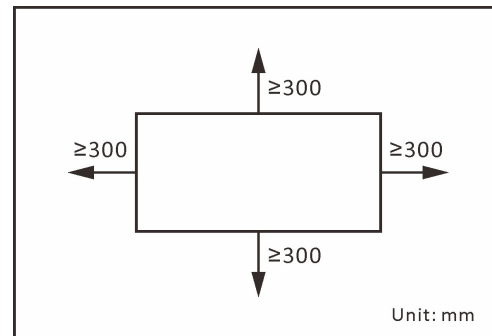
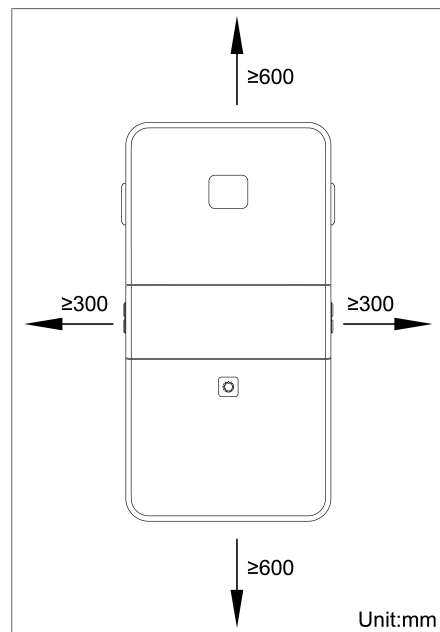

5.2 Mounting the Inverter (with AI02-BTLVP-5KWH battery)

Procedure:

STEP 1:

- Drill holes into the wall (p=12mm, drilling depth≥65mm)
- The dimensions of the back of the product are as follows (note: the height of the bottom row of holes≥200mm)
- Unscrew the M8-60 expansion screws and put the expansion head into the drilled hole.

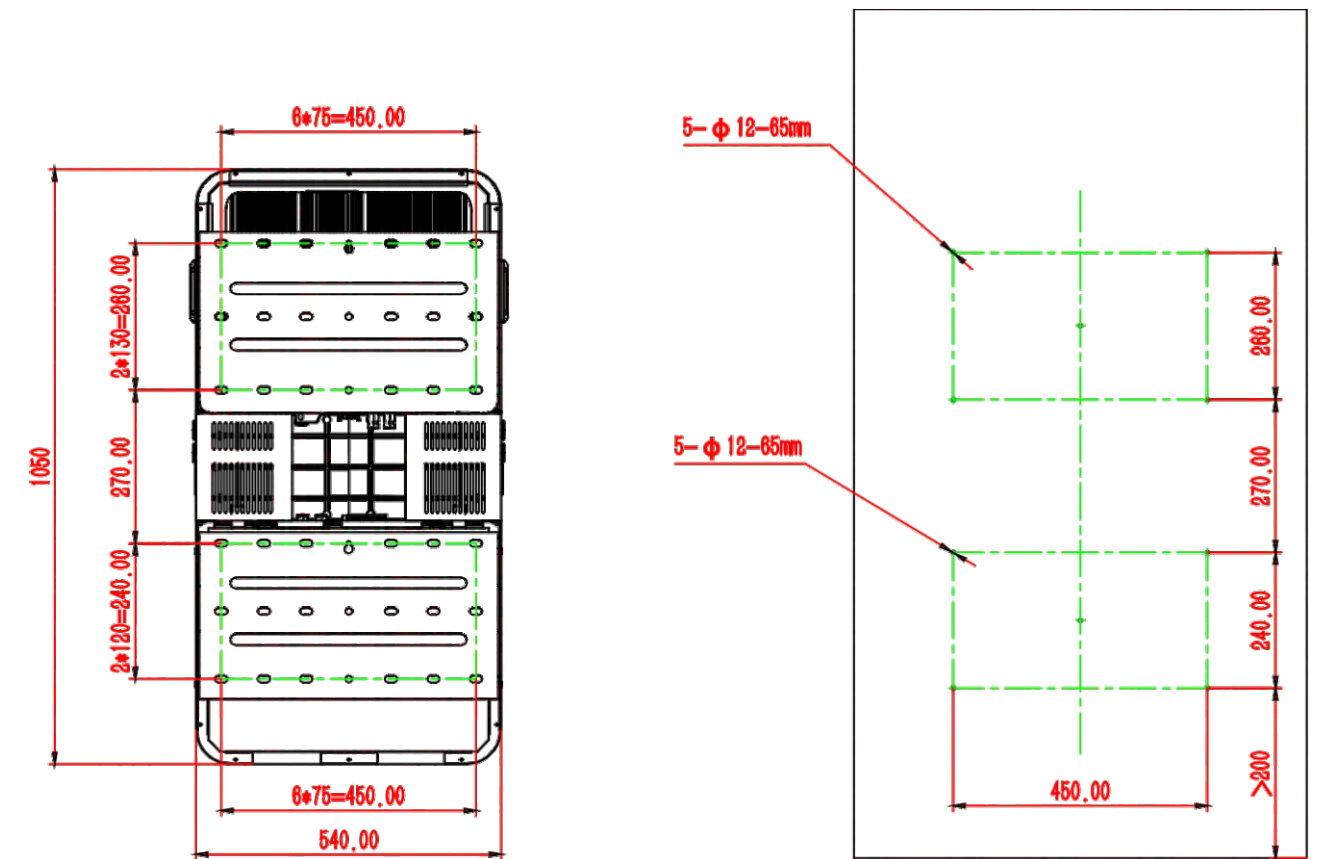

STEP 2:

- Fix the battery-bracket to the wall with 5 expansion bolts (M8-60).
Recommended torque:15N·M

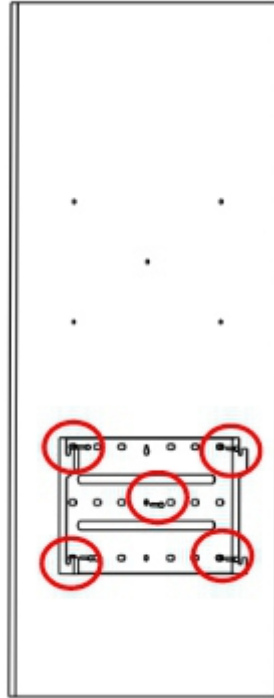

STEP 3:

- Lift and hang the battery to the battery-bracket.
- Note: Make sure that the 4 hooks of the bracket are all engaged, otherwise it will not be strong enough.

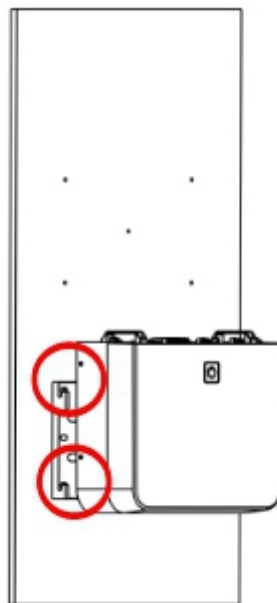

STEP 4:

- Install the outer frame of the wiring area.
- Place the frame of the wiring area on the battery, align the outer frame. Then insert the locating pins at the bottom of the frame into the locating pin holes at the top of the battery pack in the direction of the arrow

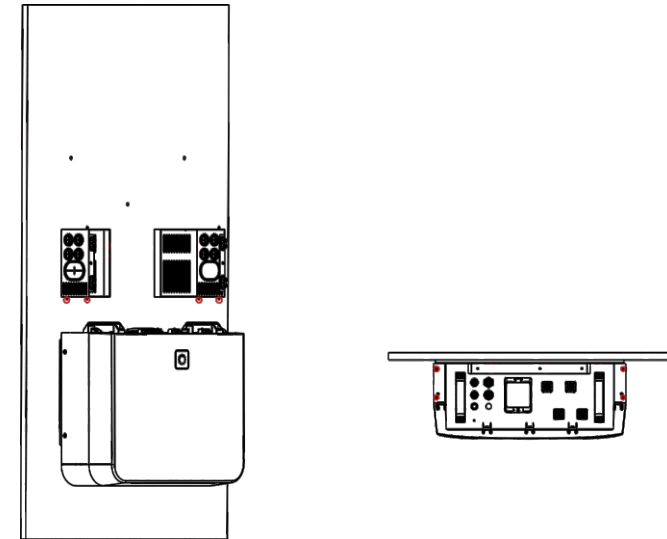

STEP 5:

- Fix the outer frame to the battery pack with 4 M5*10 screws.

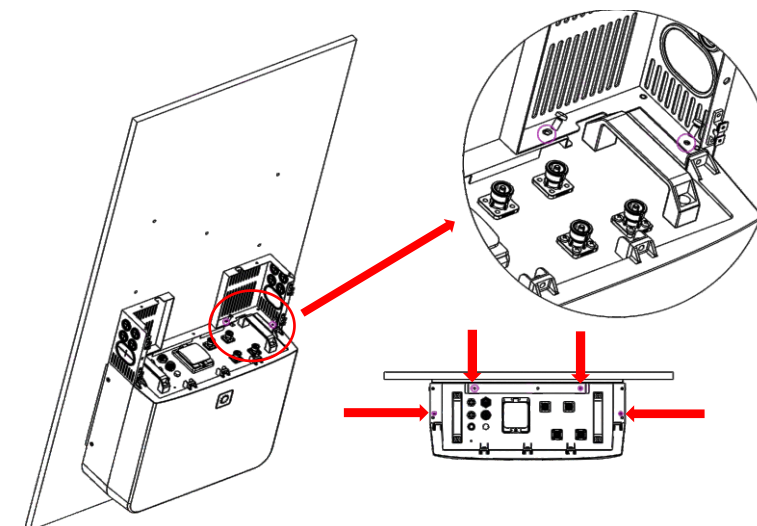

STEP 6:

- Install and secure the inverter-bracket on the wall with 5*M8-60 hex screws.

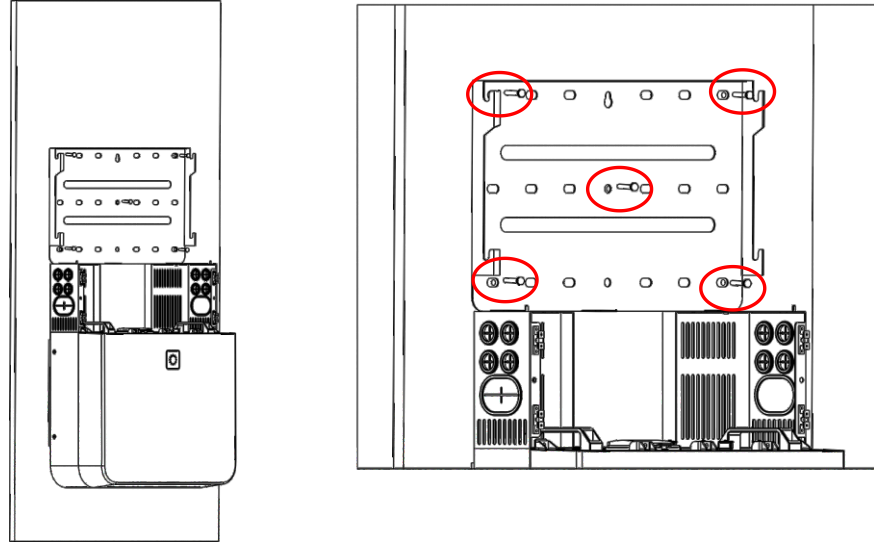

STEP 7:

- Lift and hang the Inverter to the bracket and secure with screw.
- Make sure the 4 mounting ears are perfectly engaged with the bracket.

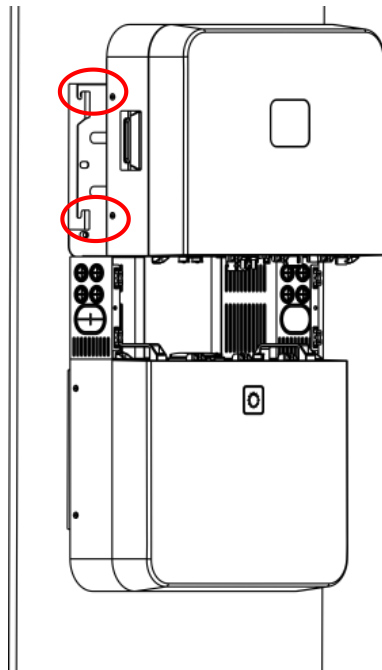

STEP 8:

- After the battery and inverter are wired, buckle the cover of the wiring area.

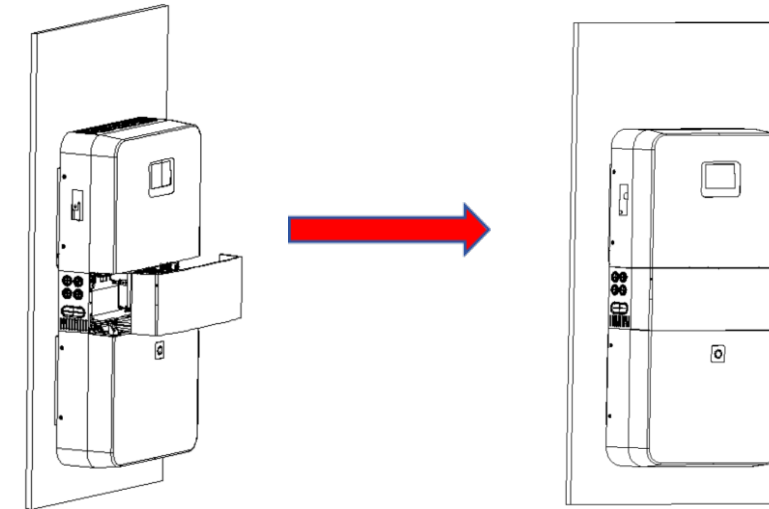

5.3 Mounting the Inverter (with AI02-BTLVP-10KWH battery)

Procedure:

STEP 1:

- Drill holes into the wall (p=12mm, drilling depth≥65mm)
- The dimensions of the back of the product are as follows (note: the height of the bottom row of holes≥200mm)
- Unscrew the M8-60 expansion screws and put the expansion head into the drilled hole.

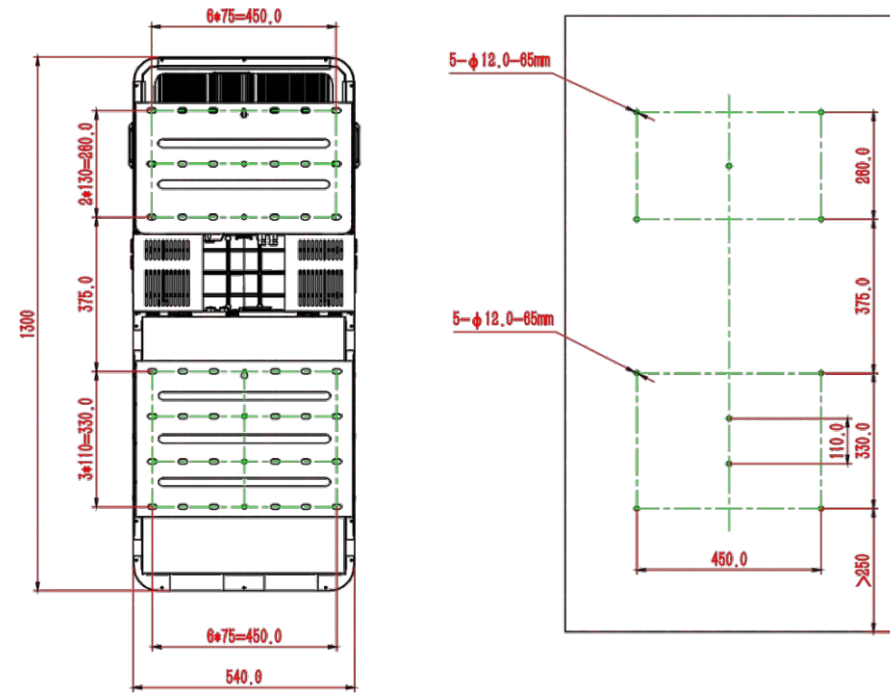

STEP 2:

- Fix the battery-bracket to the wall with 5 expansion bolts (M8-60).

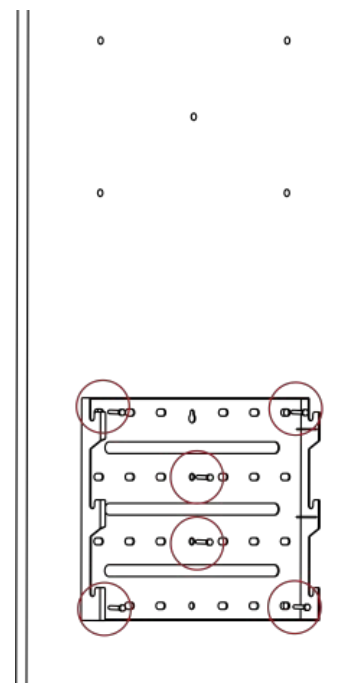

STEP 3:

- Lift and hang the battery to the battery-bracket.
- Note: Make sure that the 6 hooks of the bracket are all engaged, otherwise it will not be strong enough.

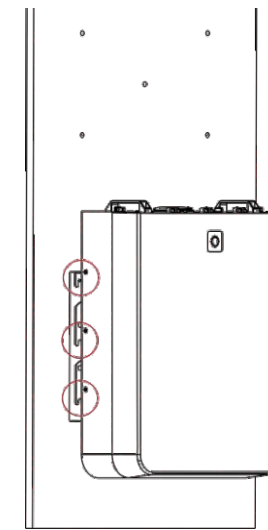

STEP 4:

- Install the outer frame of the wiring area.
- Place the frame of the wiring area on the battery, align the outer frame. Then insert the locating pins at the bottom of the frame into the locating pin holes at the top of the battery pack in the direction of the arrow

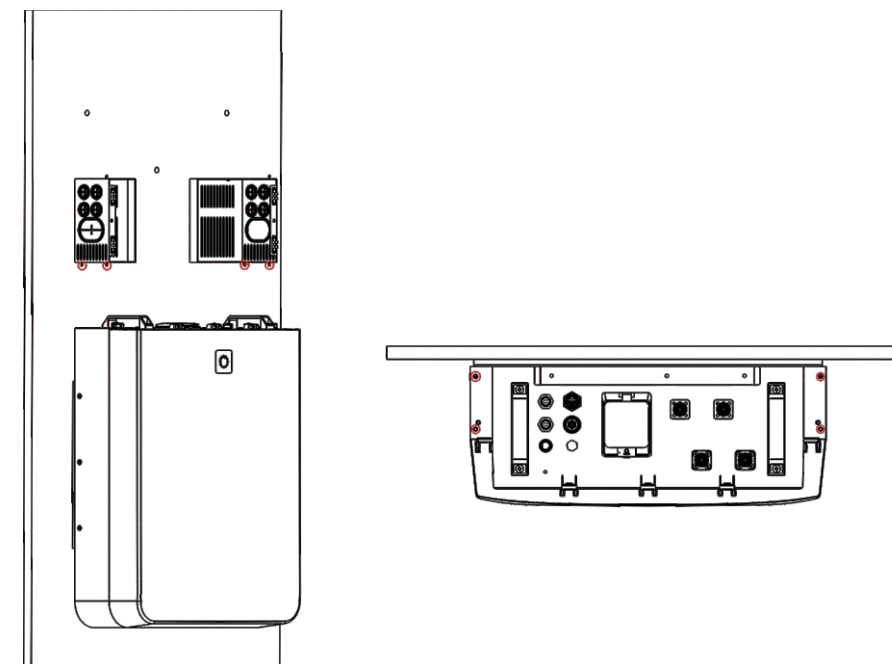

STEP 5:

- Fix the outer frame to the battery pack with 4 M5*10 screws.

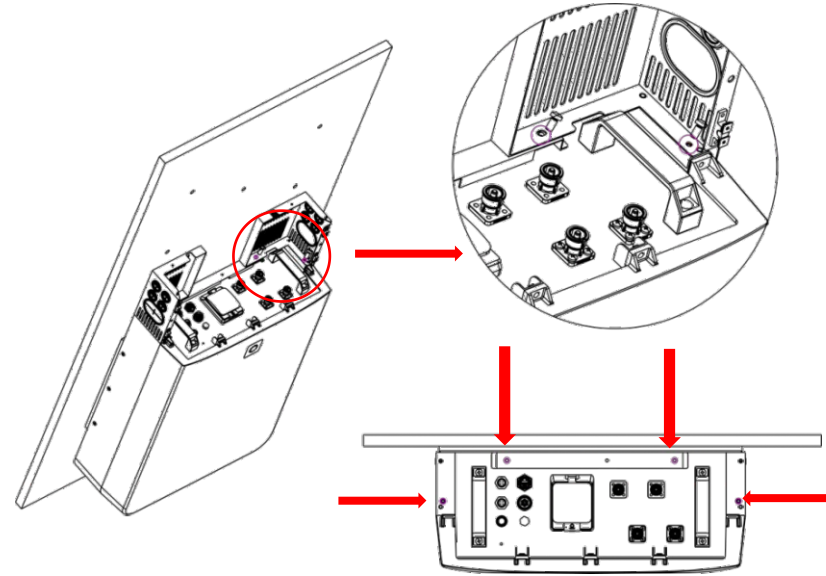

STEP 6:

- Install and secure the inverter-bracket on the wall with 5*M8-60 hex screws.

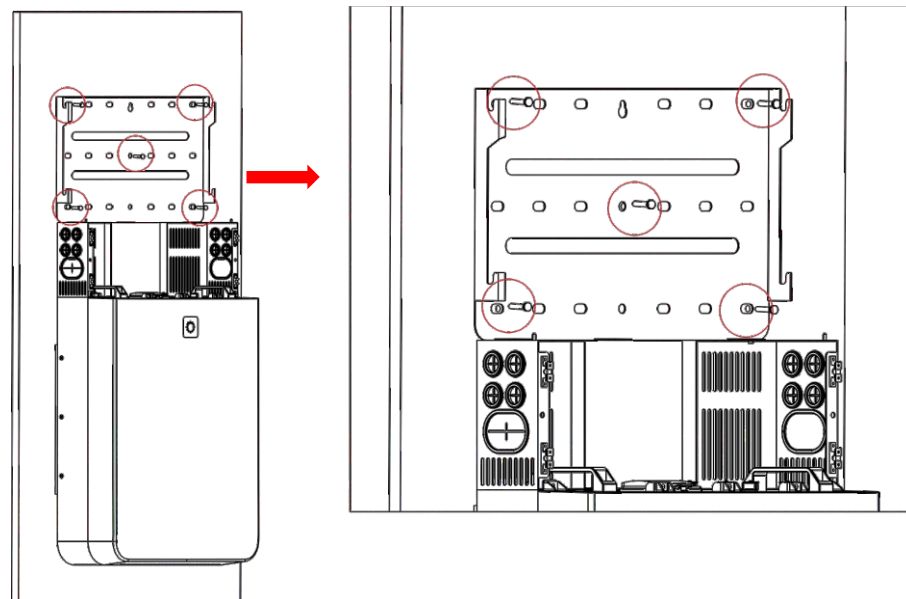

STEP 7:

- Lift and hang the Inverter to the bracket and secure with screw.
- Make sure the 4 mounting ears are perfectly engaged with the bracket.

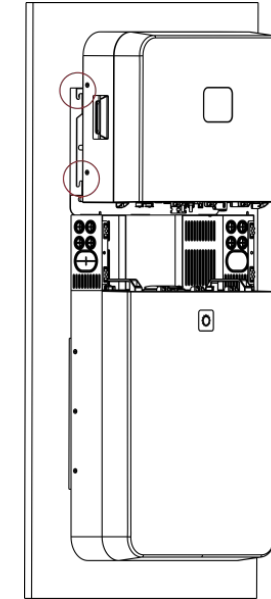

STEP 8:

- After the battery and inverter are wired, buckle the cover of the wiring area.

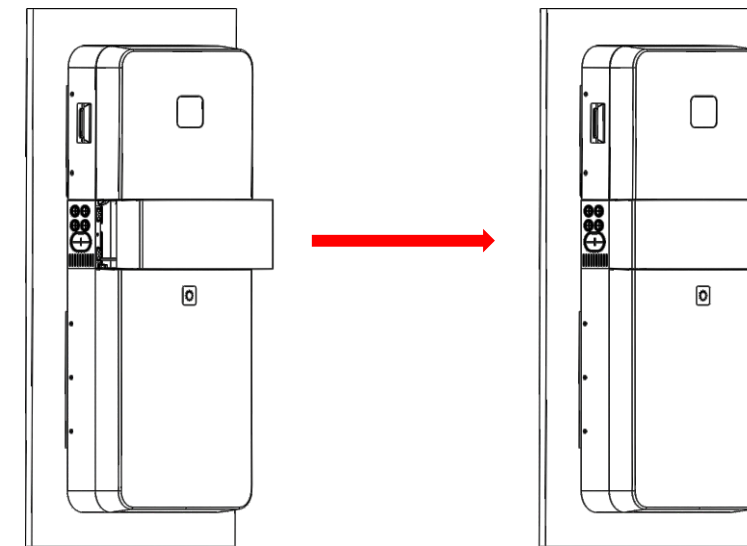

6. Electrical Connection

6.1 Wiring Diagram for Austr

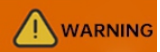
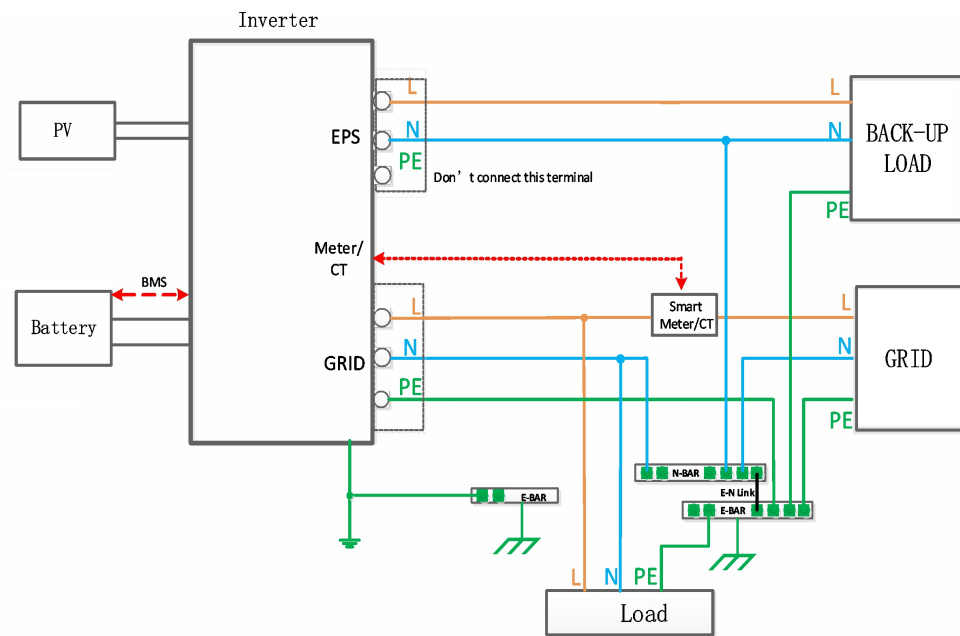

- In Australia and New Zealand, electrical installation and maintenance shall be conducted by a licensed electrician and shall comply with Australia/New Zealand National Wiring Rules.
- Because the inverter does not maintain neutral integrity during grid failure, an external neutral connection must be used in Australia and New Zealand. 30mA Type "A" RCD can be used on EPS loads.

6.2 Wiring Diagram for General

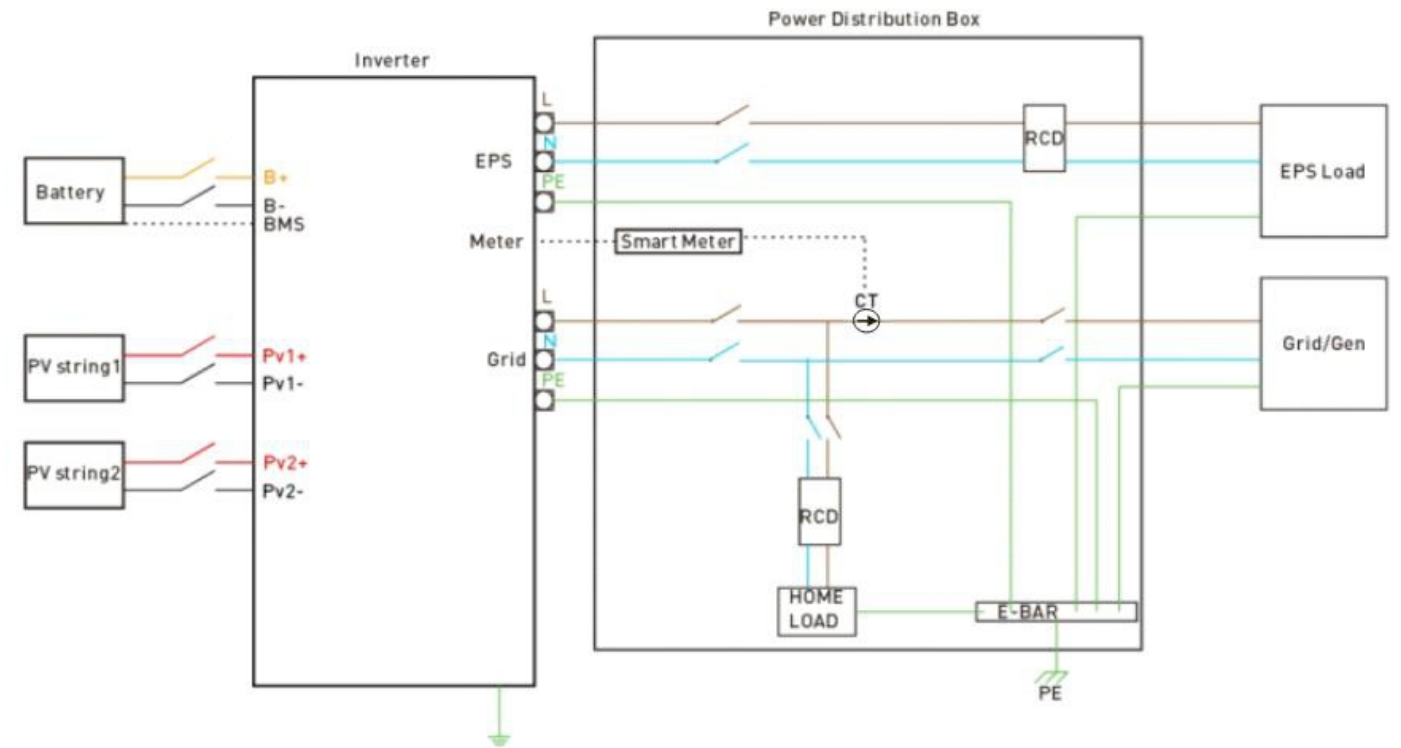

6.3 Overview of the Connection Area

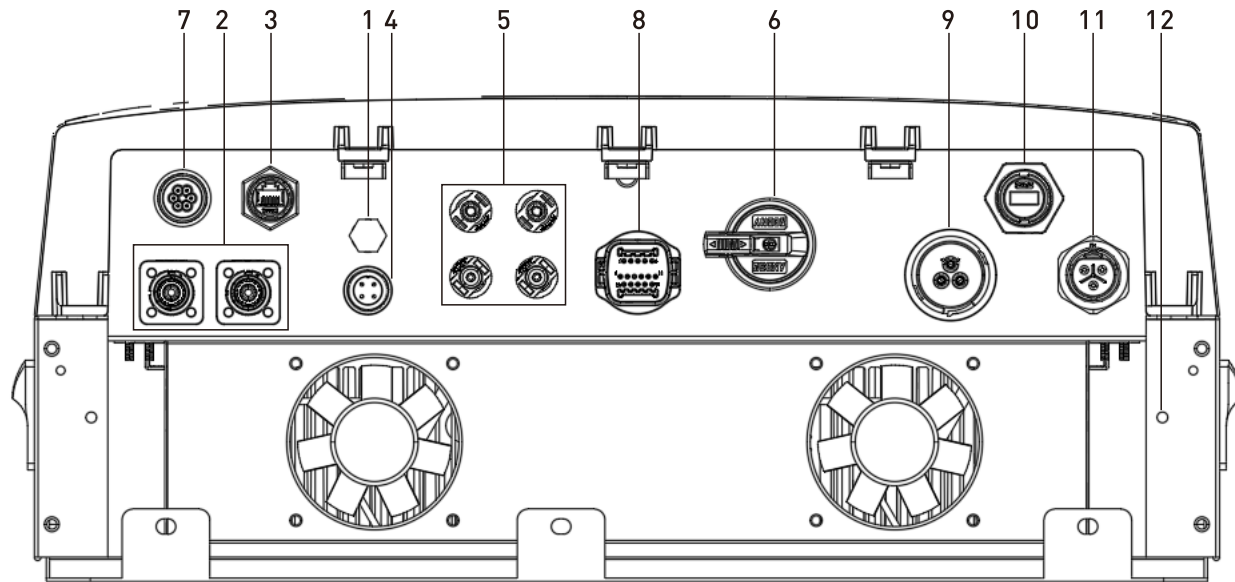

Position	Description
1	Breathable valve
2	Battery Connectors
3	DRM Port
4	EMS Port (for Wi-Fi Stick or other EMS Controllers)
5	PV Inputs
6	DC Switch (optional, mandatory for Australia)
7	BMS Port
8	COM Port
9	Grid Connector
10	USB interface (software upgrade)
11	EPS Output
12	Additional Grounding Point

6.4 PV Connection

Please only use the PV connectors from the accessory box for connection.

Before connecting, please make sure:

- The voltage, current and power ratings of the panels to be connected are within the allowable range of the inverter. Ensure polarity is correct. Please refer to the Technical Data in chapter 9 for voltage and current limits.
- Since the inverter is transformerless, please do not ground either output of the PV panels. Ground the panel frames.
- The 3.68kW/5KW inverter is designed with 2 MPPT trackers, if the inputs of the PV panels are paralleled, please consult with your local distributor for technical support.
- If the inverter is equipped with a PV switch, please make sure it is in the "off" position. Otherwise please use an external PV switch to switch off the PV connection during wiring and when necessary for maintenance.

Procedure:



WARNING

- Use IEC61730 class-A Rating PV modules.
- When exposed to light, PV panels will generate DC voltage.
- Turn off the PV switch before connecting any wiring.

STEP1:

- Strip the insulation from each PV cable by 6-8 mm.
- Assemble the cable ends with the crimping pliers.
- Lead the cable through the cable gland and connect PV cable to PV connectors.
- Screw the cable gland and the insulator.



NOTICE

- Measure the voltage of every String using a Multi-meter.
- Ensure that the polarities of the DC input power cables are correct.
- Maximum PV input voltage: 600V (taking into account voltage changes at the lowest temperature)
- Maximum PV input current: 16A

STEP2:

- Check the positive and negative polarity of the PV strings.
- Connect the PV connectors to the corresponding terminals until a “click” sound is heard.
- Seal the unused PV terminals with the terminal caps.

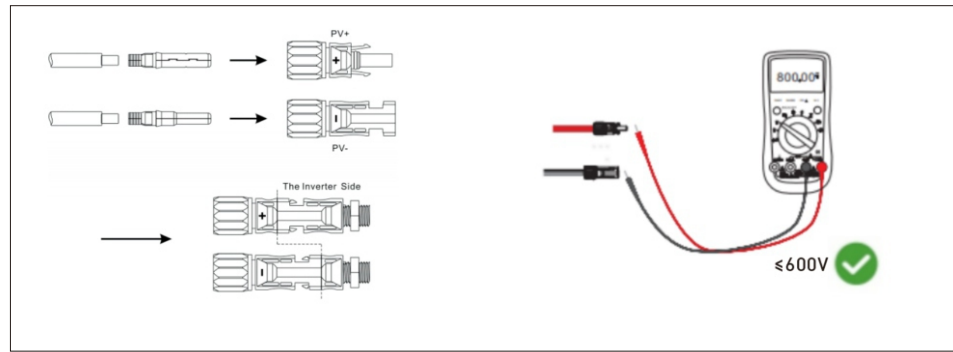

6.5 Grid Connection

Please use the Grid connector from the accessory box for connection. Before connecting, please make sure:

- The grid voltage and frequency must be in the permissible range.
- An external AC switch (≥32A) must be used on the Grid connection to cut the inverter off from the Grid when necessary.

Procedure:

STEP1:

- Disassemble the Grid connector.
- Select appropriate cables and strip the AC wires about 9mm.
- Pass the cable through the nut and sleeve of socket element.
- Connect the wires to the terminals according to the identification on the terminals and tighten them with allen wrench.

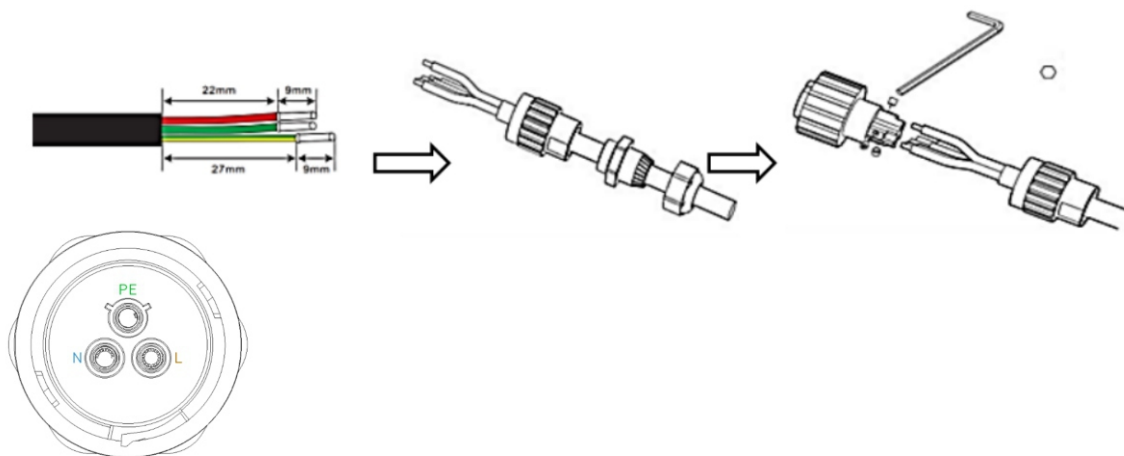

STEP2:

- Connect the Grid connector to the Grid port on the inverter, and rotate the clamp clockwise.
- Install the included shroud to prevent access to live parts.



High leakage current!

- Earth connection essential before connecting supply.

6.6 EPS Connection

If you want to use the energy storage system to power the house (as a standalone system or during Grid failure), the EPS connector should be used and the EPS function should be enabled during setup.

Before connecting, please check the following:

- The grid voltage and frequency must be in the permissible range.
- An external Change over switch to bypass the inverter and power EPS loads directly from the grid must be installed. Changeover switch must not allow connection of EPS circuit to Grid. A 3-position switch with intermediate OFF position and a minimum current rating of 32A is recommended.
- An external AC switch (≥30A) must be used on the EPS connection to cut off the inverter from EPS load when necessary.

Procedure:

STEP1:

- Disassemble the EPS connector.
- Select appropriate cables and strip the AC wires about 9mm.
- Pass the cable through the nut and sleeve of socket element.
- Connect the wire to the terminal and fasten the wire using a cross screw driver.
- Insert the EPS connector and hear “click”, then tighten the waterproof nut.

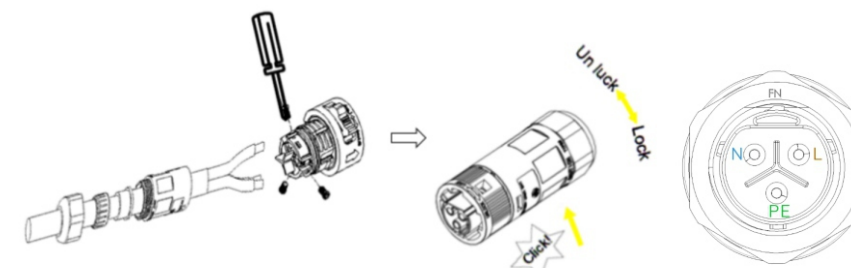

STEP2:

- Connect the EPS plug to the inverter.
- Turn the EPS connector knob to lock until you hear a "click" and the clasp is in place.

NOTICE

- Before mating the plug and socket, please double check both Grid and EPS connectors. Do not connect the grid cables to the EPS port or connect the EPS cables to the Grid Port. Otherwise, it will lead to malfunction or damage.

Declaration for backup loads:

- Soltaro AI02-INSP inverter is able to supply a continuous 6000VA output (max 9000W for 10s) on EPS side. Inverter will shutdown under full loading with high ambient temperature if grid is absent. Extra battery may be required to achieve full inverter surge capacity.
- (Any load with high inrush current at start-up is not supported on EPS circuit).

NOTICE

- Soltaro AI02-INSP series inverter is intended to be used as a backup supply for residential loads only.
- Any commercial or industrial usage of the backup supply should be checked with Soltaro support, as there may be extra requirements or limitations.

NOTICE

- When installing equipment, the protective grounding wire must be installed first; When dismantling equipment, the protective grounding wire must be removed last.
- The pulling force after crimping should be greater than 400N.
- Protective earth wire conductor cross-sectional area: 4-6mm². The wire must comply with outdoor usage standards.
- M4 pan head screw, recommended torque 2N·m.

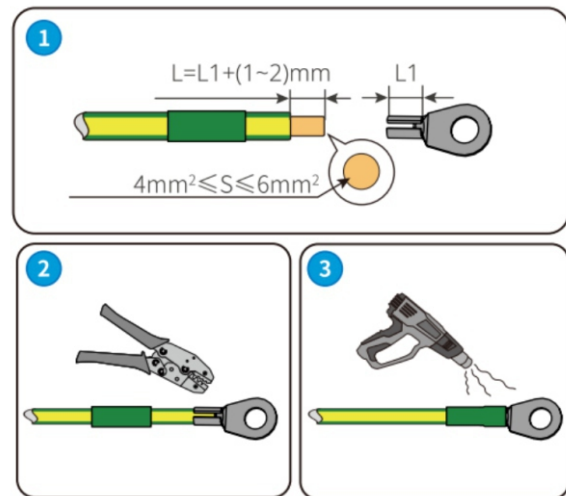

6.7 Battery Connection

6.7.1 Battery connection diagram

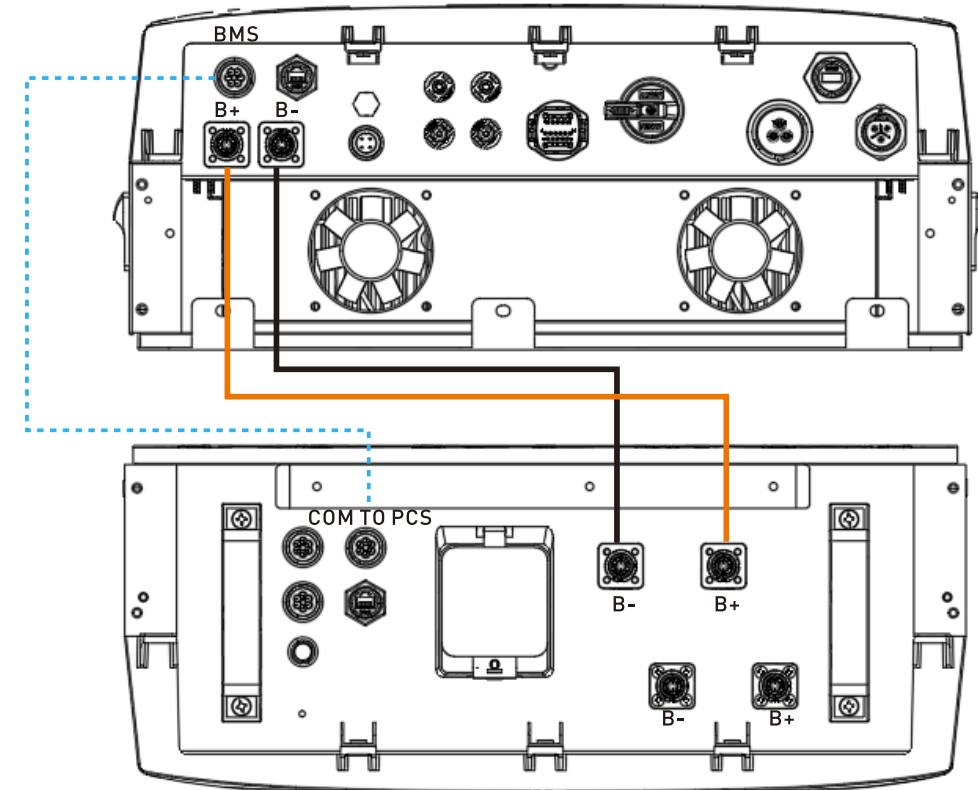

DANGER

- Be careful against any electric shock or chemical hazard.
- Only use properly insulated tools to prevent accidental electric shock or short circuits. If insulated tools are not available, use electrical tape to cover the entire exposed metal surfaces of the available tools except their tips.
- Connect battery cables with correct polarity. If battery cables are reversely connected, the solar inverter may be damaged.
- All wiring must be performed by a professional person.
- Do not disconnect under load! Battery can be placed in a no loads state by shutting down the inverter completely.

6.7.2 Battery Power Connection

Procedure:

STEP1:

- Please use the pre-assembled battery power wire in the accessory box for connection.

STEP2:

- Connect the battery cables to the inverter. A “click” sound will indicate firm connection.



- A DC breaker with OCP capability must be installed between inverter and battery. Soltaro Batteries have this switch integrated.
- Please note that the waterproof cover of the IP65 battery circuit breaker should be closed and locked after installation.

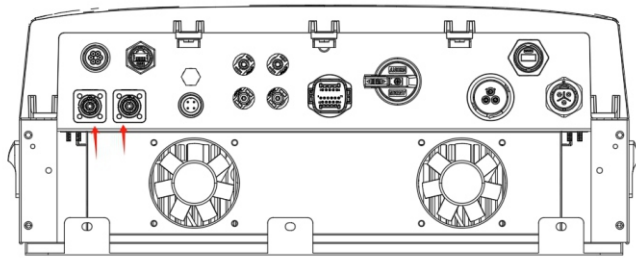

6.7.3 BMS Communication Connection

Please check whether the BMS communication cable in the accessory box is appropriate for the battery. If you are not sure, please confirm with your battery vendor.

Procedure:

STEP1:

- Insert the BMS cable connector into “BMS” port on the inverter and screw it tightly.

STEP2:

- Insert other side of communication cable into “COM to PCS” port on the battery.

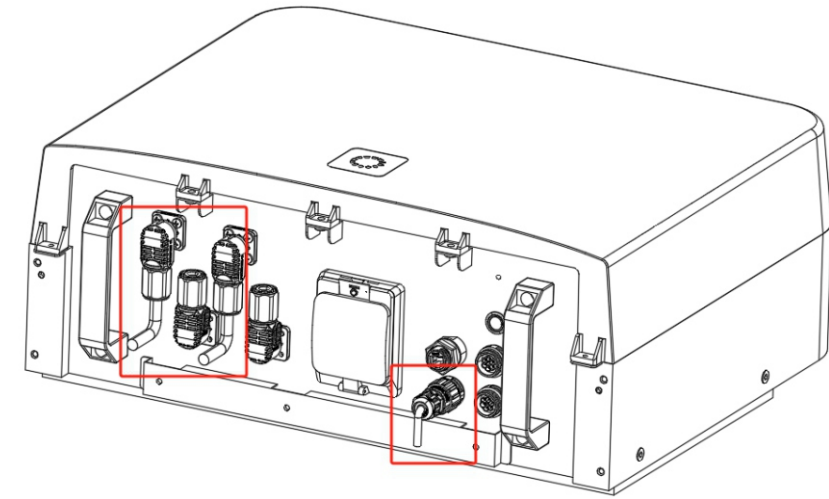

BMS Connector Pin Definition



PIN	Definition
1	BMS_CAN_H
2	BMS_CAN_L
3	NULL
4	NULL
5	NULL
6	NULL

6.8 Smart Meter Connection

The inverter provides 16pin multi terminals to facilitate you to install Smart meter or other communication.

NOTICE

- Follow the pin definition below to connect the Multi port communication cables.
- Do not remove any resistors or short circuit wire unless you are going to use the corresponding PINs.

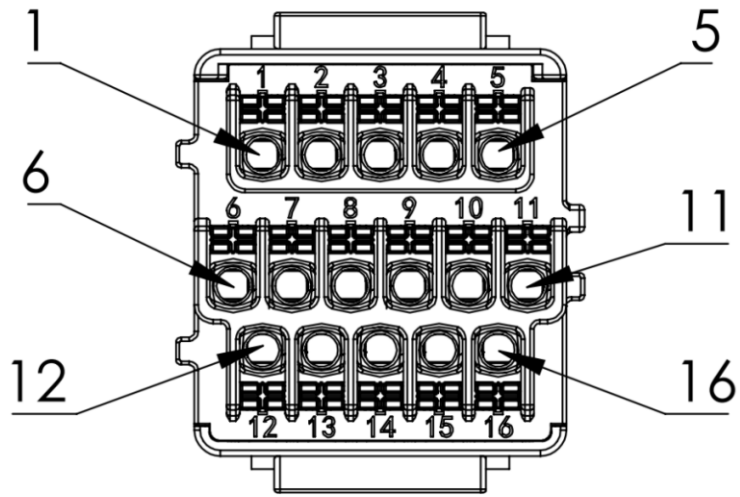

Pin	Definition	Description	Pin	Definition	Description
1	485B	485 contact interface for Smart meter	9	PWM.SYNC.CAN.H	Paralleling-CAN-1
2	485A		10	PWM.SYNC.CAN.L	
3	CT-	Contact interface for ct	11	ZERO.SYNC.CAN.H	Paralleling-CAN-2
4	CT+		12	ZERO.SYNC.CAN.L	
5	ZERO.SYNC.CAN.H	Paralleling-CAN-1	13	PAR_CAN_H	
6	ZERO.SYNC.CAN.L		14	PAR_CAN_L	
7	PAR_CAN_H		15	PWM.SYNC.CAN.H	
8	PAR_CAN_L		16	PWM.SYNC.CAN.L	

Procedure:

STEP1:

- Assemble the Smart Meter communication cable.
- Prepare the Smart Meter communication cable and take out the 16pin Multi connector and terminal pins from the package.
- Remove the cable jacket and strip the wire insulation by 0.5~12 mm.
- Insert the wires into the corresponding terminal pin and crimp them.
- Check all the wires are firmly installed.

Meter Connector Pin Definition

PIN	1	2
Definition	485B	485A

STEP2:

- Disassemble the 16pin Multi connector, then take out the Housing and remove one rubber plug from the Sealing. To avoid water and dust, keep the rubber plug to seal the unused holes.

16pin Multi connector show as below:

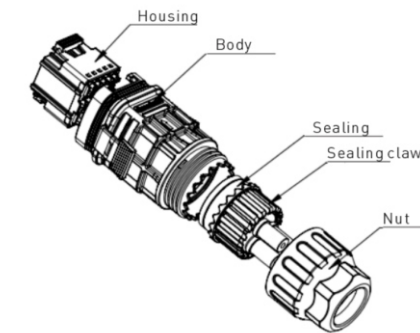

STEP3:

Feed the Smart Meter communication cable through the Nut, Sealing claw, Sealing, and the Body in sequence.

STEP4:

Insert the cables of the smart meter communication cable into the corresponding terminals on the Housing.

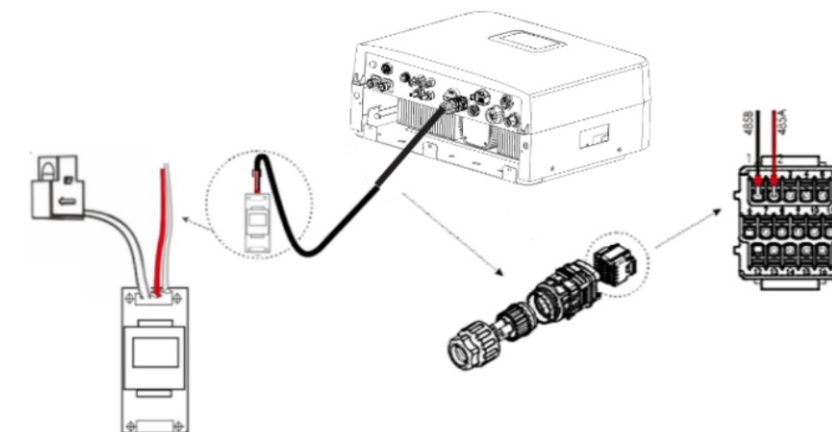

STEP5:

Assemble the 16pin Multi connector and plug it into the communication terminal on the inverter.

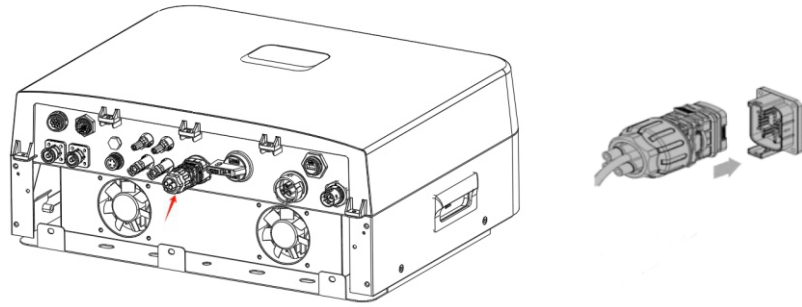

Smart Meter:

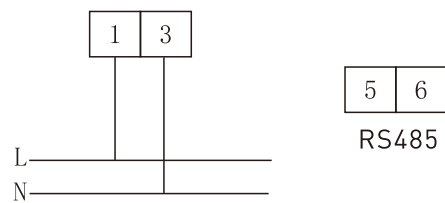
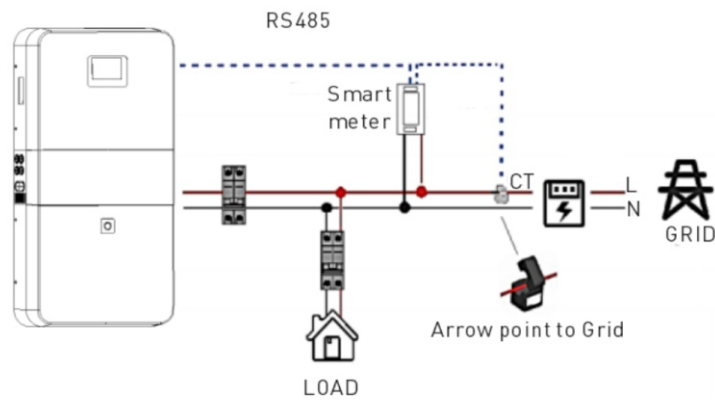

6.9 Qendercore Hub Connection

The inverter provides a communication port, which can collect data and transmit data of the inverter to the Cloud server via Qendercore Hub (Wi-Fi& LAN 2in1 function) to monitor the data status. For more details, refer to the Qendercore Hub Manual available on the Soltaro Website.

Procedure:

- Insert the Wi-Fi stick to the COM-1 port and fasten the nut tight.

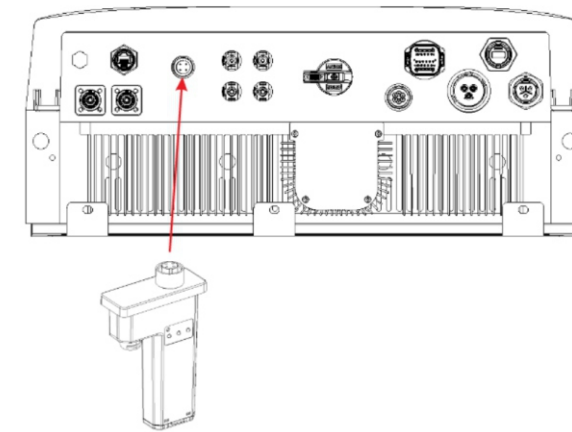

“EMS” Connector Pin Definition

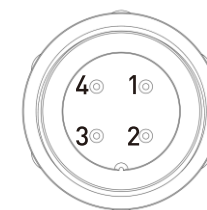

PIN	Definition
1	+5V
2	GND
3	RS485A
4	RS485B

6.10 DRM Connection

DRM is provided to support several demand response modes by certain control signals.

“DRM” Connector Pin Definition

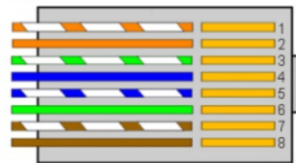

PIN	Definition	PIN	Definition
1	DRM1/5	5	REF GEN/0
2	DRM2/6	6	COM LOAD/0
3	DRM3/7	7	V+
4	DRM4/8	8	V-

7. Operating of the Inverter

7.1 Graphical Display

The graphical display shows the detailed information of the inverter.

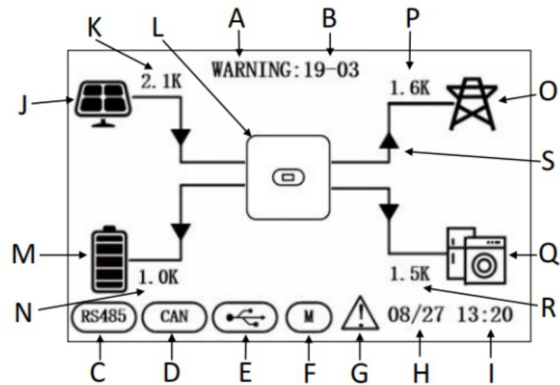

Position	Description
A	Inverter status
B	Fault alarm code
C	485 communication
D	CAN communication
E	USB
F	Electricity meter
G	Fault Alarm
H	Date
I	Time
J	PV Input
K	PV power
L	Hybrid inverter
M	Battery (divided into 5 compartments, with each compartment representing 20%)
N	Battery power
O	Grid
P	Grid power
Q	Key loads
R	Load power
S	Energy flow indicator arrow

7.2 Operating of the Battery

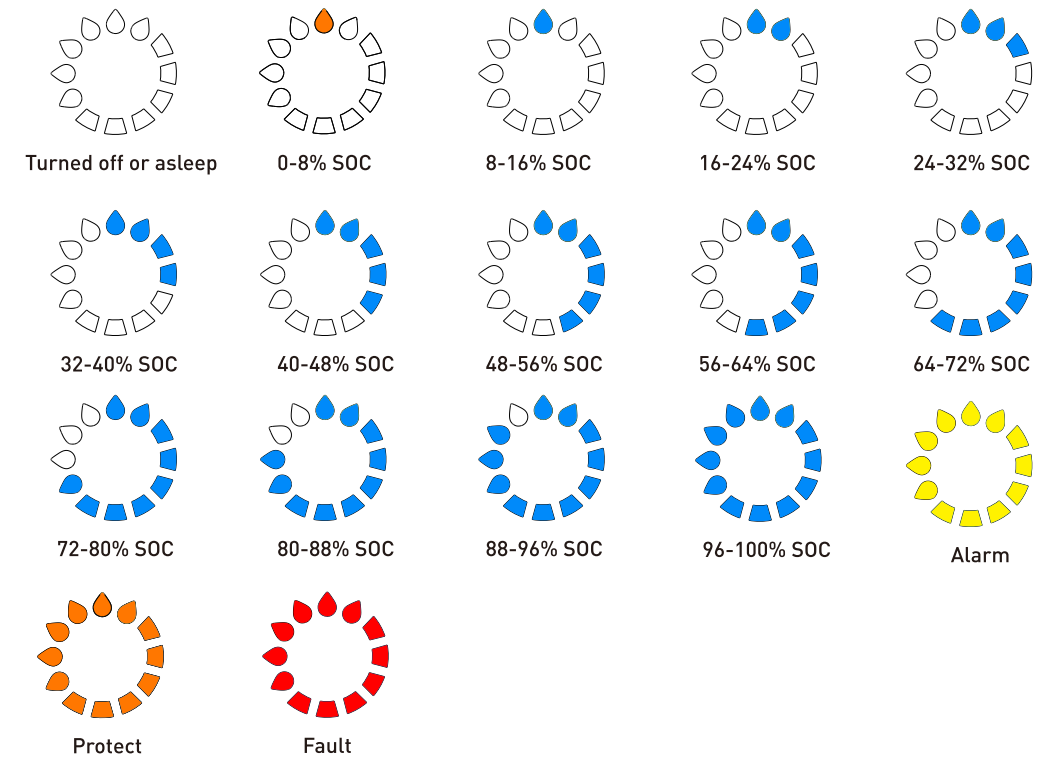

The Soltaro-logo shaped LED indicator shows the status of the battery system. When the battery is working normally, the LED will be lit up blue. There are 12 bars, indicating the usable energy of the battery (SOC). When there is an Alarm, the LED will be lit up yellow. When there is a Protect Alarm, the LED will be lit up orange. When there is a Fault, the LED will be lit up red.



7.3 Commissioning

Before commissioning the inverter, make sure:

- The country mark on the box is in accordance with the installation site;
- The inverter is correctly and firmly mounted;
- The circuit breaker is correctly connected and is in "off " position
- All cables are connected according to chapter 6;
- Unused inputs must be sealed using the corresponding connectors or sealing plugs.

- Step1:Close the AC circuit breaker on the GRID side of the inverter.
- Step2:Close the DC circuit breaker on the BAT side of the inverter.
- Step3:Close the AC circuit breaker on the EPS side of the inverter.
- Step4:Close the inverter PV SWITCH.
- Step5:Configure the Wi-Fi stick

Configure the Wi-Fi stick for remote monitoring. Please follow the instruction manual in the Wi-Fi stick's packing box. Otherwise please contact Soltaro for detailed instructions.

NOTICE:When the photovoltaic, power grid, and battery are all normal, the system will operate in "on grid mode". At this time, the green LED light is constantly on, and the energy storage machine screen displays "State: On Grid".

7.4 Decommission

- Step1:Turn off the load;
- Step2:Turn off the PV;
- Step3:Turn off the Battery;
- Step4:Turn off the main grid switch;
- Step5:Wait for at least 5 minutes after the LED and graphical display black out for the internal circuits to discharge energy;
- Step6:Disconnect all the power cables;
- Step7:Disconnect all the communication cables;
- Step8:Remove the inverter from the wall, also remove the bracket if necessary;
- Step9:Pack the inverter inside the original carton, and store it.



7.5 Network Configuration

Network configuration is necessary for online monitoring and after-sales support. All inverter settings are available via connection to the Qendercore Hub included with your Soltaro AI02.

Before attempting monitoring setup, please navigate to the Qendercore web portal at <https://www.qendercore.com/> and register a Qendercore user account. These account details will need to be entered to setup monitoring for your Soltaro AI02.

For details about Wi-Fi Configuration and system settings please refer to the Qendercore User Manual found on the Soltaro Website.

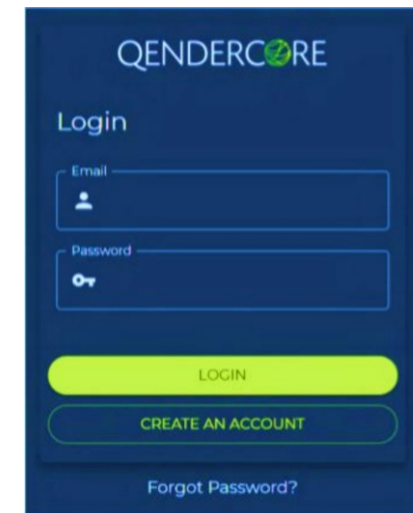

7.5.1 Connect to the Inverter

Procedure:

Please follow the instructions in the included Qendercore Installation Manual to connect to the inverter to access and adjust settings as required. All settings are protected by a password.

7.5.2 Check the Country

Each country code represents corresponding local protective parametersthat have been preset before delivery.



Procedure:

Step1:Enter the Setting interface

- Enter the Settings interface, click "Basic Settings";

Step2:Set the country

- Check the "Country", make sure it is your current location;
- If it is not your current location, please choose the right country, and click "Apply" to save the setting.



The inverter complies with AS/NZS 4777.2:2020, people in Australia need to select the corresponding Australia Region A/B/C for grid protection settings and power quality response modes settings. Please contact your local grid operator for which region to select.

7.5.3 Export Power Limit

You can set Grid Feed Power Limitation value (W) to enable Export Power Limit when your local grid operator allows limited external power feed into grid.



- Only effective when smart meter connected in the system.
- If you use this function and set a Power limit value, then PV production could be limited if consumer load or battery charge power is low.

STEP 1: Enter the Setting interface

- Go to Settings interface, click "Basic Settings".

Step2:Set the Export Power Limit/Inverter Power Limit

- Set Value of the Grid Feed Power/Inverter Power to allowable grid export/inverter output, according to your situation and/or local regulations;
- Inv. Power Limitation (W): the allowable output power of the hybrid inverter (Default: Inverter nameplate power)
- Export Power Limitation(W): Default value "0KW" means Export Power Limit OFF, no limit on export to grid.
- Click "OK", to save the settings.



7.5.4 Check Firmware & Time Synchronization

You can check the Inverter's SN, Firmware version and do Time Synchronization on the same page. It is recommended to perform Time Synchronization first after the inverter is installed and successfully connected to the Qendercore APP and then to set or modify the parameters.

Procedure:

Step1:Enter the Setting interface

- Go to the Settings interface, click "Inverter Operations".

Step2:Check Firmware

- You can check the Serials(SN),Hardware code or firmware on this page.

STEP 3: Time Synchronization

- Click "Time & Date Sync." to calibrate and synchronize time. Inverter time and date can be synchronized to Qendercore Servers if internet connection is available. Otherwise, it can be synced to the device connected to the inverter.

7.5.5 Volt-Var Settings

The steps to set the Q(U) mode via Qendercore APP are:

- 1) Go to Settings interface, click "Basic Settings"
- 2) Enable the "Reactive Power Control Mode" to "Q(U)" and set the reactive power value under "Volt Response Setting".

7.5.6 Volt-watt settings

The steps to set this function via Qendercore APP are:

- 1) Go to Settings interface, click "Basic Settings"
 - 2) Input the Voltage and active power ratio under "Volt Response Setting".
- Note: volt-watt in discharging mode and charging mode both can be set in "Volt Response Setting".

8. Troubleshooting and Maintenance

8.1 Troubleshooting

This chapter is a guide for troubleshooting problems that may arise in the installation and operation of AI02 Series inverters.

Inverter fault code:

No	Fault Type	Fault code	fault information	Solution measures
1	PV Voltage fault	01-01	PV low voltage	Please check if the photovoltaic panel connection is normal, and if there is any damage, surface dust, or obstruction on the panel.
		01-02	PV high voltage	Please check if the photovoltaic panel is connected properly and if the panel voltage specification is higher than the operating voltage range of the inverter.
		01-03	PV panel short circuit	Please check if there is a short circuit in the photovoltaic panel.
2	BUS voltage error	03-01	BUS low voltage	Please check if the photovoltaic panel connection is normal, and if there is any damage, surface dust, or obstruction on the panel.
		03-02	BUS high voltage	Please check if the photovoltaic panel is connected properly and if the panel voltage specification is higher than the operating voltage range of the inverter.
		03-04	Hardware bus overvoltage	Please restart the inverter. If the fault persists, please contact the dealer.
3	Overcurrent fault	05-01	Inverter hardware overcurrent	Please restart the inverter. If the fault persists, please contact the dealer.
		05-02	Inverter software overcurrent	
		05-03	BOOST hardware overcurrent	
		05-04	BOOST software overcurrent	
		05-05	Auxiliary source hardware TZ fault	
		05-06	Bus hardware TZ overvoltage	
		05-07	LLC side hardware TZ fault	
		05-08	Buck Boost software overcurrent	

Inverter fault code:

No	Fault Type	Fault code	fault information	Solution measures
4	Abnormal temperature fault	06-01	Inverter temperature abnormal	Please check the temperature of the inverter. If the temperature is too high, please cool it down before use.
		06-02	BOOST temperature abnormal	
		06-03	Radiator temperature abnormal	
		06-04	Environmental temperature abnormal	
		06-05	Buck Boost temperature anomaly	
		06-06	NTC open circuit	
5	Insulation detection fault	07-01	Insulation detection fault	Please confirm if the inverter and photovoltaic panel are reliably grounded. Please turn off the power for 5 minutes and then turn it back on. If the fault cannot be cleared, please contact the dealer.
6	Drive malfunction	08-01	Drive malfunction	Please restart the inverter. If the fault persists, please contact the dealer.
7	Communication failure	09-01	Master DSP receiving ARM communication fault	Please restart the inverter. If the fault persists, please contact the dealer.
		09-02	Communication failure of ARM receiving master DSP	
		09-03	Slaver DSP receiving ARM communication fault	
		09-04	Communication failure of ARM receiving slaver DSP	
		09-05	Master-slave chip communication failure - master chip failure	
		09-06	Master-slave chip communication failure - slaver chip failure	
		09-07	DSP and AFCI communication failure	

Inverter fault code:

No	Fault Type	Fault code	fault information	Solution measures
8	Leakage current fault	10-01	High static leakage current	1.If it happens occasionally,, it may be caused by an abnormal external circuit, and restarting the inverter will restore normal operation. 2. If it frequently occurs or cannot be restored for a long time, Please check whether the grounding of the PV panels is reliable.
		10-02	30mA mutation fault	
		10-03	60mA mutation fault	
		10-04	150mA mutation fault	
9	Relay malfunction	11-01	Relay open circuit	Please restart the inverter. If the fault persists, please contact the dealer.
		11-02	Relay short circuit	
10	Internal fan malfunction	12-01	Internal fan malfunction	Please restart the inverter. If the fault persists, please contact the dealer.
11	DCI malfunction	14-01	R-phase DCI fault	Please confirm if the inverter and photovoltaic panel are reliably grounded. Please turn off the power for 5 minutes and then turn it back on. If the fault cannot be cleared, Please contact the dealer.
12	Consistency failure	19-01	Inconsistent AC voltage detection	Please restart the inverter. If the fault persists, please contact the dealer.
		19-02	Inconsistent BUS voltage detection	
		19-03	Inconsistent ISO voltage detection	
		19-04	Inconsistent PV voltage detection	
		19-05	GFCI inconsistency	
		19-06	Bus voltage sampling abnormality	
		19-07	Abnormal PV current sampling	
13	Power grid voltage fault	31-01	Under voltage level 1 of the mains power supply	1.If it happens occasionally, it is a momentary abnormality in the power grid. After the power grid returns to normal, the inverter will resume normal operation; 2.If this fault is frequently reported, please check if the power grid is abnormal.
		31-02	Overvoltage level 1 of the mains power supply	
		31-03	No mains voltage	Please check if the mains power is normal.

Inverter fault code:

No	Fault Type	Fault code	fault information	Solution measures	
13	Power grid voltage fault	31-04	Secondary undervoltage of the municipal power supply	1.If it happens occasionally, it is a momentary abnormality in the power grid. After the power grid returns to normal, the inverter will resume normal operation; 2.If this fault is frequently reported, please check if the power grid is abnormal.	
		31-05	Secondary overvoltage of mains power		
		31-06	Undervoltage during startup of mains power		
		31-07	Overvoltage during mains power start-up		
		31-08	Interrupt instantaneous overvoltage		
	14	Mains frequency fault	31-09	Island overvoltage	1.If it happens occasionally, it is a momentary abnormality in the power grid. After the power grid returns to normal, the inverter will resume normal operation; 2.If this fault is frequently reported, please check if the power grid is abnormal.
			31-10	Voltage oscillation in the power grid	
			33-01	Under frequency 1st order of municipal power supply	
			33-02	Overfrequency 1st order of mains power	
			33-03	Under frequency 2nd order of municipal power supply	
15	remote shutdown	33-04	Overfrequency 2nd order of mains power	1.If it happens occasionally, it is a momentary abnormality in the power grid. After the power grid returns to normal, the inverter will resume normal operation; 2.If this fault is frequently reported, please check if the power grid is abnormal.	
		33-05	Underfrequency of mains power startup		
		33-06	Overfrequency of mains power startup		
15	remote shutdown	37-01	Remote shutdown command	Please check if the inverter has been manually turned off.	
16	AFCI malfunction	38-01	String 1 malfunction	Please shut down the inverter and disconnect the input/output switch. After 5 minutes, restart the inverter. If the fault cannot be cleared, please contact the dealer.	
		38-02	String 2 malfunction		



Inverter fault code:

No	Fault Type	Fault code	fault information	Solution measures
17	AFCI self-test fault	39-01	String 1 self-test fault	Please shut down the inverter and disconnect the input/output switch. After 5 minutes, restart the inverter. If the fault cannot be cleared, please contact the dealer.
		39-02	String 2 self-test fault	
18	AutoTest malfunction	41-01	Automatic test failure fault	Please shut down the inverter and disconnect the input/output switch. After 5 minutes, restart the inverter. If the fault cannot be cleared, please contact the dealer.
19	N-PE fault	42-01	N-PE voltage abnormal fault	Please check if the AC side wiring of the inverter is correct and secure.
20	Leakage current self-test fault	43-01	Leakage current sensor malfunction	Please shut down the inverter and disconnect the input/output switch. After 5 minutes, restart the inverter. If the fault cannot be cleared, please contact the dealer.
21	String detection fault	44-01	String fault	Please shut down the inverter and disconnect the input/output switch. After 5 minutes, restart the inverter. If the fault cannot be cleared, please contact the dealer.
22	Auxiliary power failure	45-01	Auxiliary power supply loses power	Please shut down the inverter and disconnect the input/output switch. After 5 minutes, restart the inverter. If the fault cannot be cleared, please contact the dealer.
23	EPS short circuit fault	46-01	EPS short circuit fault	Please check if the EPS port output wiring is correct.
24	Parallel machine malfunction	40-1	Multiple host failures	Please check the master and slave settings
		40-2	Parallel CAN communication failure	Please check the parallel CAN wiring
		40-3	Host loss fault	1.Please check the parallel CAN wiring 2. Please check the master and slave settings
		40-4	Synchronization zero crossing fault	1.Please check the parallel CAN wiring 2. Please check the master and slave settings



Inverter alarm code:

No	Fault Type	Fault code	fault information	Solution measures
25	Low fan speed	01-07	Internal fan 1	Please shut down the inverter and disconnect the input/output switch. After 5 minutes, restart the inverter. If the fault cannot be cleared, please contact the dealer.
26	Anti backflow meter communication	04-01	Electric meter abnormal warning	Please check if the wiring of the electricity meter is abnormal and if the power supply is normal.
		04-08	Electric meter communication abnormality warning	Please check if the wiring of the electricity meter is abnormal and if the power supply is normal.
		04-16	CT wiring abnormality warning	Please check if the CT wiring is normal.
27	Grid out of range alarm	05-00	Voltage out of range alarm	1.If it happens by chance, it is a momentary abnormality in the power grid. After the power grid returns to normal, the inverter will resume normal operation; 2.If this fault is frequently reported, please check if the power grid is abnormal.
28	PV short circuit alarm	06-01	PV1 short circuit alarm	Please check if the photovoltaic input is abnormal and if there is a short circuit in the circuit.
		06-02	PV2 short circuit alarm	
29	Overload alarm	07-01	EPS overload alarm	Please reduce the load power on the EPS end.
30	Battery fully charged	46-01	Battery fully charged	The battery is fully charged.
31	Battery depletion	47-01	The battery needs to be charged	Please charge the battery.
		47-02	The battery can only be charged	Please check the mode settings and charge the battery.
32	EPS overload alarm	07-01	EPS power exceeds 1.5 times	Please reduce the load power on the EPS end.
		07-02	EPS power exceeds 1.2 times	
		07-03	EPS power exceeds 1.1 times	
		07-04	EPS current exceeds 1.5 times	
		07-05	EPS current exceeds 1.2 times	
		07-06	EPS current exceeds 1.1 times	



8.2 Maintenance

To ensure that the inverter can operate properly for a long term, you are advised to perform routine maintenance on it as described in this chapter.



- Risk of inverter damage or personal injury due to incorrect service!
- Always keep in mind that the inverter is powered by 3 sources: PV strings, battery and utility grid.
- Before cleaning the system, connecting cables, and maintaining the grounding reliability, power off the system (see 7.3 Decommission the System for details)

Maintenance list

Check Item	Method	Period
Inverter operation status	Observe whether the inverter is securely installed and whether there is any damage or deformation. Listen for any abnormal sounds during the operation of the inverter. Check all variables during system grid connection operation. Check if the heating of the inverter casing is normal, and use a thermal imaging device or other monitoring system to monitor the heating situation.	Once every six months
Inverter cleaning	Check the humidity and dust around the inverter. If it affects the machine's heat dissipation, please stop the machine and turn off the power. After the machine cools down, use a soft brush or dry cloth to clean it.	Once every six months
Electrical connection	Check if the system cable connections are loose and if the inverter wiring terminals are loose. Check for any damage to the cable, especially if there are any cut marks on the surface in contact with the metal.	Once every six months
dc switch	Connect the DC switch and turn it on and off 2 times to ensure that the DC switch functions properly	Once a year
tightness	Check if the sealing of the equipment inlet hole meets the requirements. If there are gaps that are too large or not sealed, they need to be re sealed	once a year
Safety function	Check the inverter LCD and system shutdown function. Simulate shutdown and check the shutdown signal communication. Check the warning label and replace it promptly if necessary.	Once a year



9. Technical Data

9.1 Specification of inverter

Inverter Model	AIO2-INSP-3680	AIO2-INSP-5000	AIO2-INSP-6000
AC Output @ Grid			
AC Input Voltage/ Frequency	230Vac/50Hz		
Rated output power (W)	3680	5000	6000
Maximum output power (VA)	4048	5500	6600
Rated output current	16A	21.7A	26.1A
Recommended circuit breaker	25A type C/D	32A type C/D	32A type C/D
THD	<3%		
Power factor	0.8 leading to 0.8 lagging		
AC Output @ Off Grid			
AC Output Voltage /Frequency	230Vac/50Hz		
Maximum output power (VA)	3680	5000	6000
Maximum output current	16A	21.7A	26.1A
Rated current	16A	21.7A	26.1A
Peak output power, time (KW, s)	5.5,10	7.5,10	7.5,10
THDv (@ rated power)	<3%		
Switching time (ms)	<10		
Solar Input			
Full load range	280-500V		
Max. PV array power(W)	5400	7500	9000
Max. Voltage of Open Circuit	600Vdc		
MPPT Voltage Range	100-550Vdc		
Starting voltage (V)	100		
Rated voltage (V)	360		
Max. input current	16Adc		
Max.PV Isc	24Adc		
Num.of MPP Trackers	2		
Battery Input			
Battery Type	Lithium Battery		
Battery Voltage	40~60Vdc		

Inverter Model	AI02-INSP-3680	AI02-INSP-5000	AI02-INSP-6000
Maximum charge and discharge current (A)	90A	100A	100A
BMS Communication	CAN		
Protection	Over Voltage, Under Voltage, Over Current, Short Circuit, Over Temperature		
Efficiency			
Max. Battery Discharge Efficiency	95.00%		
Max Efficiency	97.50%		
European Efficiency	97.20%		
General Data			
Dimensions	540*443*210mm(Inverter)		
Weight	32KG		
Mounting Information	Wall Mount		
Operating Temperature	-30°C to +60°C		
Relative Humidity	0 to 100%RH		
IP Protection Type	IP65		
Protective class	Class I		
Cooling Concept	Fan Cooling		
Sound pressure	<35		
Site Altitude	<2000		
Overvoltage Category	III(Mains) II(DC)		
Recommended installation scenarios	Outdoor		
Pollution degree	PD3(external), PD2(internal)		

9.2 Specification of battery

Battery Model	AI02-BTLVP-5KWH	AI02-BTLVP-11KWH
Electrical Data		
Cell Type	LFP	
Total Energy	5kWh	11kWh
Max. Depth of Discharge	90%	
Nominal Voltage	51.2V	
Operating Voltage Range	44.8-57.6V	44.8-56V
Capacity(Ah)	100Ah	230Ah
Rated Charge Current	50A	100A
Max. Charge Current	100A	100A
Max. Discharge Current	100A	100A

Battery Model	AI02-BTLVP-5KWH	AI02-BTLVP-11KWH
General Data		
Mounting information	Wall mount	
Communication	CAN/RS485	
Operating Temperature	5-50°C charge/-15°C-55°C discharge	10-50°C charge/-15°C-55°C discharge
Dimension(mm)	[540±3]*[459±3]*[210±3]	[540±3]*[709±3]*[210±3]
Weight(KG)	54±1	97±1
IP Protection Type	IP65	

9.3 Certificates and Grid Regulations

- EMC:
IEC/EN 61000-1/3
- Safety:
IEC/EN 62109-1/2
- Grid Regulations:
AS4777.2, EN50549, IEC 61727/62116, G98/G99, VDE 4105, C10/C11, NRS 097-2-1, CEI 0-21, UNE217001, UNE217002, RD647, NTS, BIS

10. Contacts:

Head Office & Showroom

8 Mohr Street, Tullamarine, VIC, Australia 3043
 Tel: +61 1300 276 582
 Email: service@soltaro.com Support Head Office
service.au@soltaro.com Australian Support

UK/Europe Office

Unit 8, High Grounds Industrial Est., Worksop, Notts, S80 3AF, United Kingdom
 Tel: +44 (0)1909 807 577
 Email: service.uk@soltaro.com

Website

WWW.SOLTARO.COM

Registration URL

<https://soltaro.com/product-registration>